

## WBA BANCO DI MONTAGGIO

Il banco di lavoro, specificatamente attrezzato per eseguire montaggi o assemblaggi con utensili pneumatici, è composto da una struttura in estruso di alluminio, che sostiene l'impianto A.T.S. Quest'ultimo consiste in una rotaia sulla quale scorre libero un carrello predisposto di un'uscita di aria compressa e di un aggancio utensile.

Una delle due colonne della struttura è pressurizzata, funge quindi da condotta e da serbatoio d'aria compressa.

Completano inoltre l'impianto i piedi regolabili in altezza e le traverse regolabili a cui agganciare le cassette porta-pezzi. Tutta la struttura è fornita in robusto imballo di cartone ed è già premontata, onde facilitare l'installazione del banco da parte dell'utilizzatore.

In alternativa al banco completo vi è la struttura semplice applicabile al vostro piano di lavoro.



### Caratteristiche tecniche:

- Struttura in alluminio anodizzato
- Dimensioni del piano: 75x150 oppure 200 cm
- Altezza del piano da terra: 85-95 cm
- Altezza del carrello da terra: 220 cm
- Foro di uscita aria compressa: 1/4"
- Foro di ingresso aria compressa: 3/8"





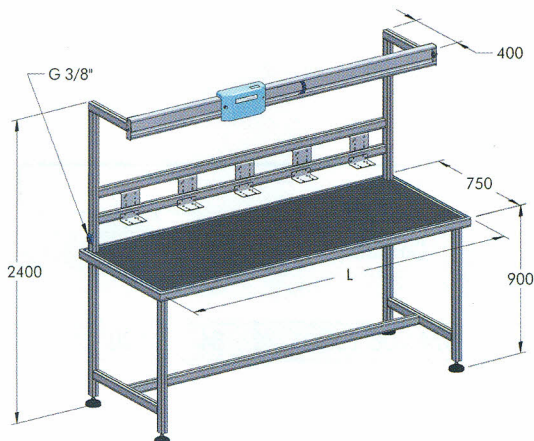

**WBA - BANCO DI MONTAGGIO COMPLETO**

Banco di montaggio completo con carrello A.T.S., supporti per cassette, piedi regolabili e colonna con alimentazione aria.





Non sono compresi: accessori e imballaggio.



L m	Codice N°	P Kg	 n°	
1,5	004 001 150	77	1	
2	004 001 200	87	1	

**ELETRIFICATO**





Come sopra, con aggiunta di cavo elettrico a bordo del carrello.

L m	Codice N°	P Kg	 n°	
1,5	004 003 150	78	1	
2	004 003 200	88	1	

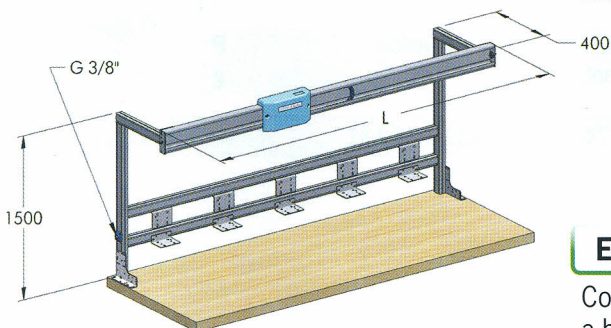
**WBA - STRUTTURA PER BANCO**





Struttura completa di A.T.S. e supporti per cassette, da fissare su un banco già esistente.



L m	Codice N°	P Kg	 n°	
1,5	004 011 150	24	1	
2	004 011 200	26	1	



**ELETRIFICATO**

Come sopra, con aggiunta di cavo elettrico a bordo del carrello.

L m	Codice N°	P Kg	 n°	
1,5	004 013 150	25	1	
2	004 013 200	27	1	

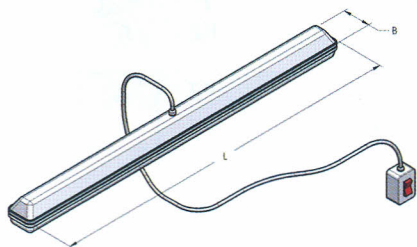
## PORTALAMPADE COMPLETO DI LAMPADA E INTERRUTTORE



B mm	L m	Codice N°	P g	 n°	
120	1,30	004 001 072	3,4	1	

## PROFILO IN PVC MORBIDO COLORE BLU

HBS MAT

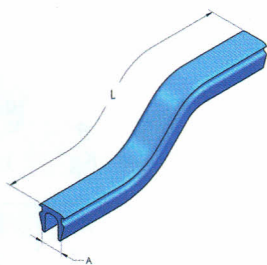

A mm	L m	Codice N°	P g	 n°
6,2	1	874 006 100	34	100

## SQUADRA DESTRA

SYS

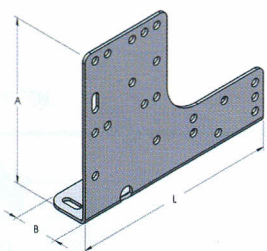

A mm	B mm	L mm	Codice N°	P g	 n°
130	36	174	732 174 130	400	20

## SQUADRA SINISTRA

SYS

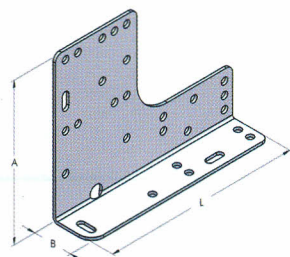

A mm	B mm	L mm	Codice N°	P g	 n°
130	36	174	732 174 131	400	20

## PIASTRA SCANTONATA

SYS

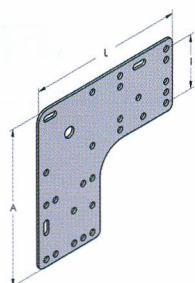



A mm	I mm	L mm	Codice N°	P g	 n°
174	36-60	174	711 174 174	400	20

**MENSOLA PER CASSETTI**

HBS

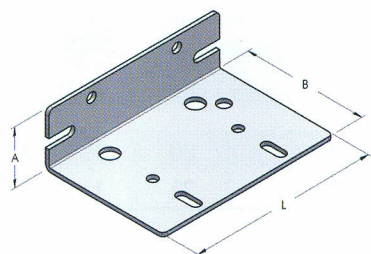
MAT



A mm	B mm	L mm	Codice N°	P g	 n°
36	80	120	732 120 115	260	20

**SQUADRA PER BANCO**

HBS

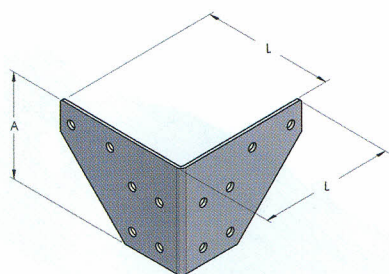

A mm	L mm	Codice N°	P g	 n°
85	110	732 085 220	280	20

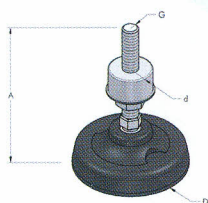
**PIEDE COMPLETO**

D mm	A mm	G mm	d mm	Codice N°	P g	 n°
80	93	12	32	004 001 070	320	10

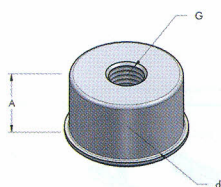

**CILINDRETTO PER PIEDE**

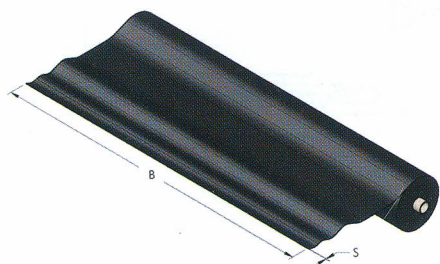
d mm	A mm	G mm	Codice N°	P g	 n°
32	30	12	512 032 030	115	20

**LASTRA IN PVC PER COPERTURA BANCHI**

S mm	B cm	Codice N°	P kg/m <sup>2</sup>	 n°
2	200	151 002 200	2	2

**BANCO DI SERVIZIO COMPLETO (IN SCATOLA DI MONTAGGIO)**

A cm	B cm	L cm	Codice N°	P Kg	n° 
90	75	150	004 021 150	30	1 
90	75	200	004 021 200	31	1 

**STRUTTURE A DISEGNO**

Il reparto tecnico Teseo è in grado di progettare, preventivare e realizzare strutture e banchi che soddisfino le esigenze proprie di ogni cliente. Naturalmente oltre a fornire soluzioni esclusive, aggiungiamo la qualità ed il know how specifici del nostro prodotto.

