

Membrane Dryers KMM Series

Flow volume at inlet up to 4.40 m³/min



Decentralised Compressed Air Drying

Why is it necessary to dry compressed air?

The atmospheric air drawn into a compressor is a mixture of gases that always contains water vapour. The amount of water vapour air can carry varies and is mostly dependent on temperature. When air temperature rises – as happens during compression – the air's ability to hold moisture increases also. When the air is cooled, its capacity to hold moisture reduces, which causes the water vapour to condense. This condensate is then removed in the centrifugal separator, or the air receiver, downstream from the compressor. Even then, the air can still be completely saturated with water vapour. This is why, as the air cools further, significant amounts of condensate can accumulate in the air distribution piping and at take-off points. Therefore, additional drying is essential to avoid production downtime and interruptions, as well as reduce costly maintenance and repair work.

How the membrane dryer module works

Moist compressed air flows into the module casing where it comes into contact with the membrane fibres. A minimal amount of this now dry compressed air is used as purge air and is drawn upwards around the fibres and expands to atmospheric pressure. The resulting increase in volume increases the air's water retention capacity. In combination with the selectivity of the membrane, the differing water content of the purge air flow and the flow of air to be dried (both flowing in opposite directions), allows water molecules – almost exclusively – to diffuse through the fibre wall. There are separate outlets for the dried compressed air and the purge air.

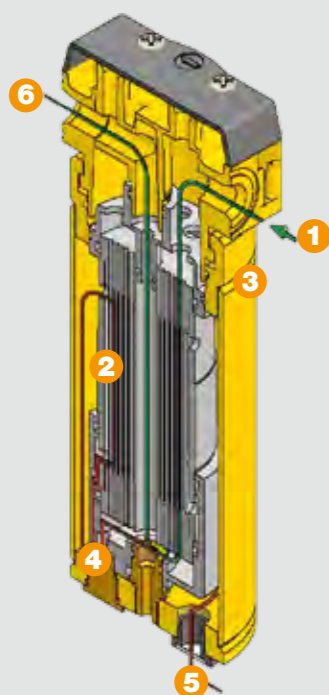

- 1 Compressed air inlet
- 2 Membrane fibre module
- 3 External casing
- 4 Purge air nozzle
- 5 Purge air outlet
- 6 Compressed air outlet

KMM – Efficient, reliable, maintenance-free

The KAESER Membrane Module (KMM) not only features the unique “Flow” concept which is designed for long-term efficient air drying and maximum service life, but also uses new highly effective hollow fibre membranes that are woven in a densely packed “helix” structure. Requiring minimal space and no additional power source, the KMM achieves pressure dew points from +3 to -40 °C.

KAESER KOMPRESSOREN – The compressed air systems provider: From the compressor right through to the air treatment equipment, all components in a Kaeser compressed air system are designed to work perfectly with one another to ensure unrivalled reliability and efficiency.



High performance “Flow” concept

The “Flow” concept of inside to outside permeation enables the highly resistant membrane fibres in the dryer insert to ensure exceptional drying results.

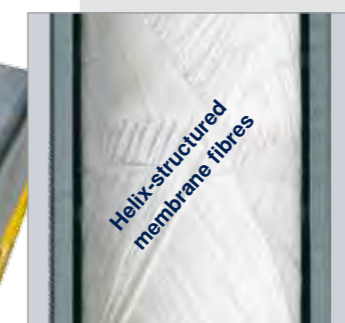

Efficient “Helix” Structure

The internally coated membrane fibres are wound in a “helix” structure that increases the fibre surface area in contact with the compressed air. This results in even air distribution and increased efficiency in a reliable, compact drying unit.



Precision Purge Air Nozzle

Precision purge air delivery via a specifically dimensioned nozzle significantly reduces operating costs, as only the required volume of compressed air for purge use is diverted.



Energy-Saving Purge Air Stop Valve (Option)

To avoid unnecessary flow of purge air, the solenoid stop valve on the purge air outlet can be set to close during times when there is no compressed air demand.

Exceptional dependability

The new KMM dryer design provides many advantages over conventional membrane dryer models, as the “Flow” concept ensures outstanding drying results through highly effective moisture removal, enhanced pressure stability and reduced differential pressure. Furthermore, in combination with KAESER compressed air filters, the design also provides protection from any contamination that may enter the dryer, as it is trapped before it can reach the sensitive membrane fibres.

KMM — Eight Decisive Advantages

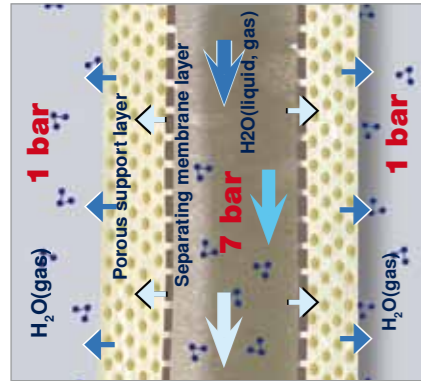

1 “Flow” Concept

Each hollow membrane fibre consists of a highly porous support layer and an internal separating membrane layer that is permeable only by water. Due to the differential pressure between the purge air and the damp compressed air, the moisture contained in the compressed air evaporates as it enters the fibres and permeates the separating membrane layer. This means that the pores in the support layer are always able to let water vapour through, even if moisture condenses on the module or fibres.



2 Outstanding Performance

The spiralled helix structure of the fibres in the inner chamber of the dryer module means that the module is now shorter, yet has the same drying capacity as previous longer models. At the same time it presents the maximum membrane surface area to the moist air and ensures an even flow of air through the fibre module. This feature, combined with the “Flow” concept, results in outstanding drying performance from a compact and highly efficient package.



3 Maximum Reliability

All functional components of the KMM dryer are integrated within a high-resilience enclosure. KAESER microfilters installed upstream from the unit protect it from potential damage from dust, aerosol and oil contamination, whilst the KMM design ensures continuous compressed air drying. The actual composition (ratio of primary components, i.e. nitrogen and oxygen) of the air remains unchanged.



4 No Additional Power Necessary

The KMM membrane dryer features a rugged housing, requires no external power source, has no moving parts and releases the moisture removed from the compressed air as harmless water vapour into the ambient surroundings. With only the pre- and after-filters requiring intermittent replacement, the dryer uses no additional consumable items.

5 Energy-Saving Purge Air Stop Valve (Option)

To avoid unnecessary flow of purge air, the solenoid stop valve on the purge air outlet can be set to close during times when there is no compressed air demand. Furthermore, the valve provides unrivalled reliability and operated perfectly for well in excess of 1 million switching sequences under rigorous testing conditions.



6 Super-fine Membrane Fibres

Compared with conventional membrane fibres, the fibres in Kaeser Membrane Modules (KMM) are much finer and far more densely packed. Consequently, the surface area available for compressed air drying is significantly larger and achieves superior drying results. The fibres are also mechanically stable, which means that they provide exceptional performance and long service life.



7 Simple Installation

The KMM dryer can be quickly and easily mounted on the wall (preferable) using optionally available mountings. Furthermore, a specially designed installation and connection set allows the KMM to be installed in combination with various compressed air filters (e.g. FG activated carbon filter).



8 Condensate Drainage Without Pressure Loss (Option)

For outstandingly safe and reliable condensate drainage, the upstream micro-filter can be equipped with an electronic ECO Drain system. The pre-filtration stage can also be monitored using a filter monitor (E-Pack version) and an optional electronic filter monitor box.



Versions and Options

KMM with FE/FF filter – Standard version



- KMM membrane dryer using the “Flow” concept and helically wound fibres
- Pre-filter equipped with a float-controlled condensate drain and pressure differential indicator
- Filter to be fitted by the user, connection components included
- Outlet silencer also included

KMM without pre-filter



- For customer-specific filter combinations
- Filter must be installed at customer's premises
- Outlet silencer also included

KMM with purge air stop valve for enhanced energy savings



- KMM membrane dryer using the “Flow” concept and helically wound fibres
- Solenoid pilot-valve: 230 V, 50 Hz, 240 V, 60 Hz, open when de-energised
- Adjusted and pre-assembled ready for immediate operation
- Outlet silencer also included



KMM with FE/FF filter, filter monitor and ECO Drain condensate drain



- Electronic monitoring of microfilter
- Microprocessor-controlled liquid crystal display
- Monitors operating time, pressure differential and most economical operating mode
- Maintenance indicator: Filter change
- Sends alarm signals via the additional monitor box to master compressed air management systems

Installation and connection set (for KMM 1-4)



Modular design for simple connection of additional filters (e.g. connection of FFG combination filter)

Metal wall bracket



Wall mounting of the KMM unit is made simple via the wall brackets

ECO-Drain condensate drain



- High performance level sensor
- Intelligent control system
- Self-monitoring
- Condensate drainage without pressure loss

Dimensions:

KMM Compressed Air Dryer

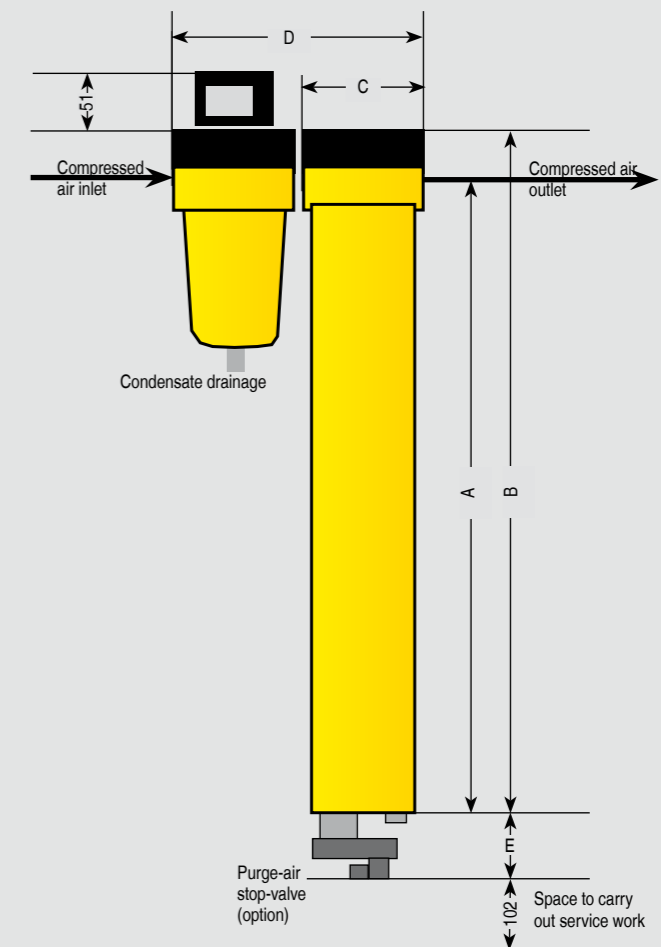

Comprehensive design know-how



- 1 Rotary screw compressor
- 2 Centrifugal separator
- 3 Refrigeration dryer
- 4 Air receiver
- 5 Aquamat
- 6 KMM dryer with filter
- 7 ECO-Drain condensate drain

Typically ensuring a load capacity of 95% or more, KAESER compressed air systems provide exceptional

efficiency and produce application specific quality compressed air at lowest possible cost. Use this expertise

to your advantage: Let KAESER design your compressed air system.

Specifications – KMM Membrane Dryer

Model	Inlet volume* (m³/min) with pressure dew point reduction			Purge air volume in m³/min	Air connection Internal thread	Dimensions in mm					Suitable pre-filter model FF/FE	Weight** in kg	
	+35° C → +3° C	+35° C → -20° C	+5° C → -20° C			A	B	C	D	E		Only dryer	With filter
KMM 1	0.04	0.02	0.04	0.01	R 3/8	260	298	105	210	120	6	2.5	6.1
KMM 2	0.13	0.08	0.13	0.02	R 3/8	362	400	105	210	120	6	2.8	6.4
KMM 3	0.28	0.16	0.26	0.04	R 3/8	464	502	105	210	120	6	3.0	6.6
KMM 4	0.38	0.24	0.38	0.06	R 3/8	664	702	105	210	120	6	3.6	7.2
KMM 5	0.68	0.40	0.67	0.10	R 3/4	473	514	133	266	120	28	4.9	9.3
KMM 6	1.17	0.74	1.12	0.16	R 3/4	670	711	133	266	120	28	6.2	10.6
KMM 7	1.97	0.98	1.83	0.30	R 1	718	762	164	320	120	48	7.6	12.4
KMM 8	3.12	1.69	2.93	0.46	R 1	819	876	194	350	132	48	15.9	20.7
KMM 9	3.97	2.27	3.81	0.59	R 1	978	1035	194	350	132	48	18.1	22.9

* As per ISO 7153, Option A: Reference point 1 bar_(abs), 20° C, Operating point: Inlet pressure 7 bar (g), Ambient temperature 20° C. – Please contact our technical department with regards to deviating operating conditions and special applications. – ** Weight of purge air stop valve approx. 1 kg

Correction factors for deviating operating conditions

Working pressure in bar (g)	5	6	7	8	9	10	11	12	13
Selected PDP ¹⁾ → Factor fPDP + 3° C	0.58	0.78	1.00	1.22	1.46	1.71	1.98	2.26	2.55
Selected PDP ¹⁾ → Factor fPDP + 20° C	0.57	0.78	1.00	1.20	1.41	1.64	1.86	2.10	2.34
Purge air → Factor fPurge	0.75	0.88	1.00	1.13	1.25	1.38	1.50	1.63	1.75

1) PDP = Pressure dew point

Purge air stop valve

Voltage (valve open when de-energised)		
Standard	230V/1ph/50Hz*	240V/1ph/60Hz*
Option	460V/1ph/60Hz**	120V/1ph/60Hz* 110V/1ph/50Hz*

*) Multi-region — **) No CE licence

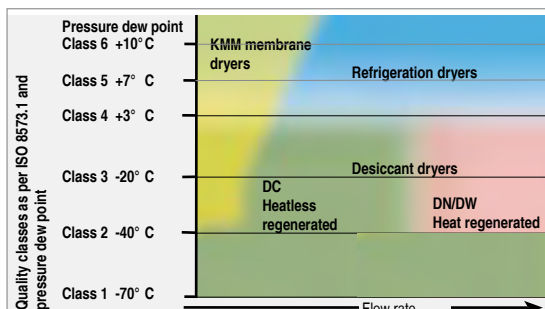

Membrane dryer applications

- Limited space and/or mobile operation (container, vehicle)
- Seasonal operation at sub-zero temperatures downstream of a refrigeration dryer for pressure dew points below +3 °C (workshops, petrol stations)
- Drying of relatively small air volumes directly at air-consuming equipment, e.g. CNC machines

Different fields of application require different grades of air treatment

Choose the required grade of treatment according to your field of application:

Air treatment with membrane dryers

Application examples: Selection of treatment classes to ISO 8573-1¹⁾

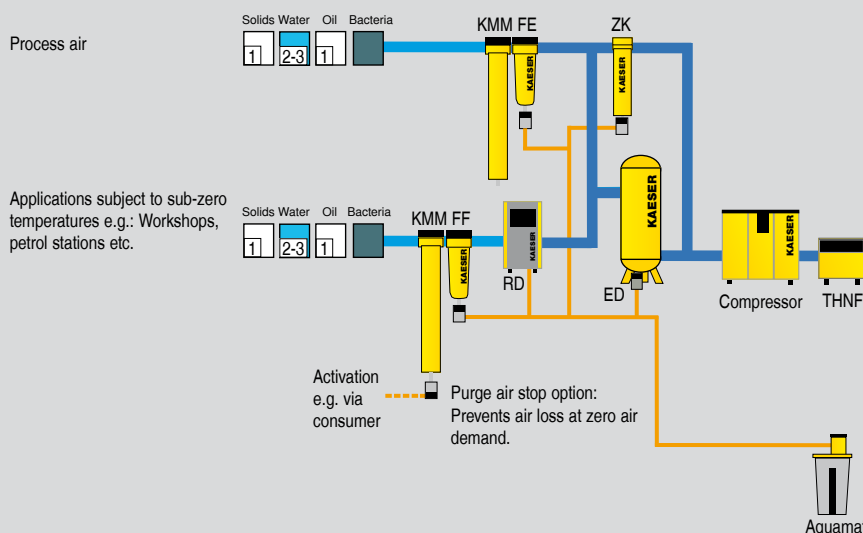

Explanation	
THNF	Bag filter
ZK	Centrifugal separator
ED	ECO DRAIN
FE / FF	Microfilter
FG	Activated carbon filter
KMM	Membrane dryer
RD	Refrigeration dryer
Aquamat	Aquamat
DHS	Air-main charging system

Compressed air quality classes to ISO 8573-1(2010):

Solid particles / dust			
Class	max. particle count per m ³ of a particle size with d [µm]*		
	0.1 ≤ d ≤ 0.5	0.5 ≤ d ≤ 1.0	1.0 ≤ d ≤ 5.0
0	e.g. Consult KAESER regarding pure air and cleanroom technology		
1	≤ 20.000	≤ 400	≤ 10
2	≤ 400.000	≤ 6.000	≤ 100
3	Not defined	≤ 90.000	≤ 1.000
4	Not defined	Not defined	≤ 10.000
5	Not defined	Not defined	≤ 100.000
Class	Particle concentration C _p in mg/m ³ *		
6	0 < C _p ≤ 5		
7	5 < C _p ≤ 10		
X	C _p > 10		

Water	
Class	Pressure dew point, in °C
0	e.g. Consult KAESER regarding pure air and cleanroom technology
1	≤ -70 °C
2	≤ -40 °C
3	≤ -20 °C
4	≤ +3 °C
5	≤ +7 °C
6	≤ +10 °C
Class	Concentration of liquid water C _w in g/m ³ *
7	C _w ≤ 0.5
8	0.5 < C _w ≤ 5
9	5 < C _w ≤ 10
X	C _w ≤ 10

Oil	
Class	Total oil concentration (fluid, aerosol + gaseous) [mg/m ³]*
0	e.g. Consult KAESER regarding pure air and cleanroom technology
1	≤ 0.01
2	≤ 0.1
3	≤ 1.0
4	≤ 5.0
X	> 5.0

*) At reference conditions 20 °C, 1 bar(a), 0% humidity

