

SAB SUPPORTO A BRACCIO GIREVOLE

Il braccio girevole per alimentazione di aria compressa, permette di sorreggere ed alimentare gli utensili pneumatici su un campo di azione a superficie semicircolare.

Esso è costituito da una barra orizzontale fissata ad un perno cavo girevole su cuscinetti auto-lubrificanti, munito di guarnizioni per la tenuta dell'aria compressa.

Questo perno è sostenuto da due supporti fissati al muro mediante tasselli, oppure, nella versione da banco, è fissato al banco stesso mediante una colonnetta.





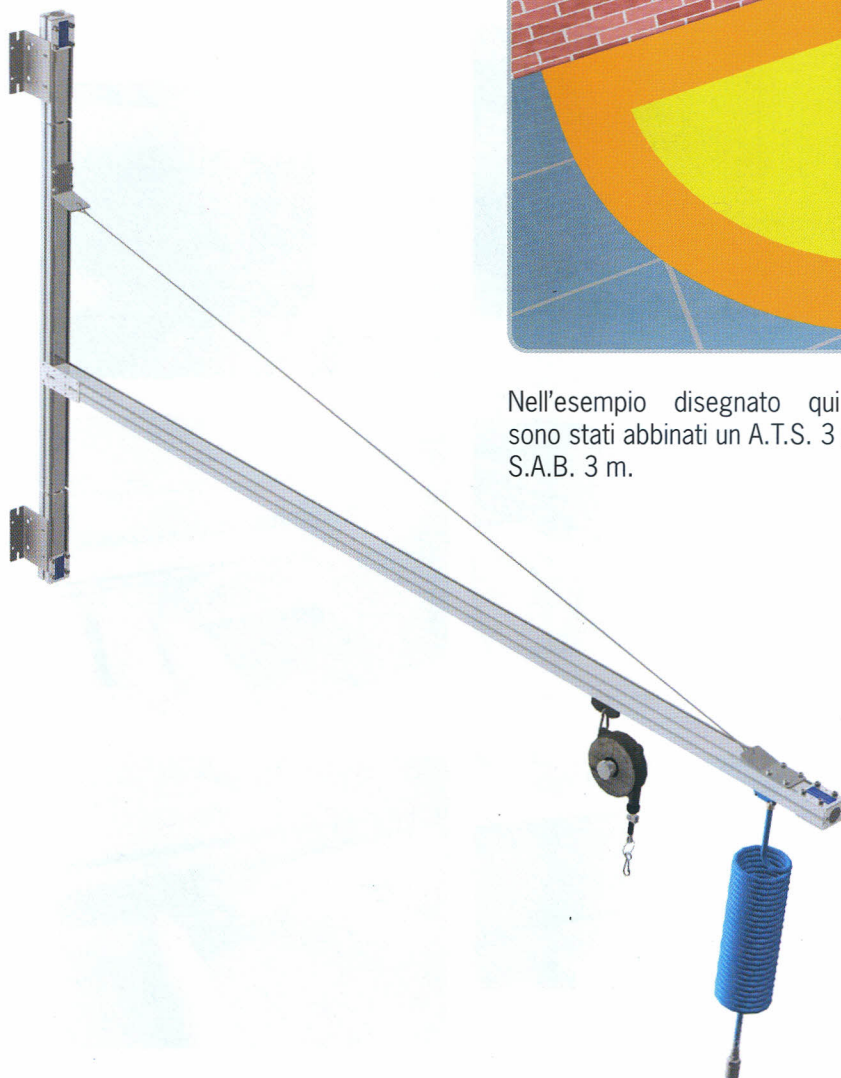

Abbinando un braccio S.A.B. con un A.T.S. è possibile combinare il movimento rotatorio con quello traslatorio. Ciò permette di coprire delle superfici di lavoro molto ampie.



Nell'esempio disegnato qui sopra sono stati abbinati un A.T.S. 3 m su un S.A.B. 3 m.



SAB - VERSIONE A PARETE

L m	Codice N°	P Kg	 n°	
2	002 001 200	11	1	
2,5	002 001 250	11,5	1	
3	002 001 300	12	1	
4	002 001 400	13	1	
5	002 001 500	14,5	1	

Braccio girevole da fissare a parete, completo di tasselli di fissaggio, di piastrina di uscita da 3/8" e di pattino scorrevole per l'aggancio dell'utensile. Il carico massimo sopportabile è di 20 kg.

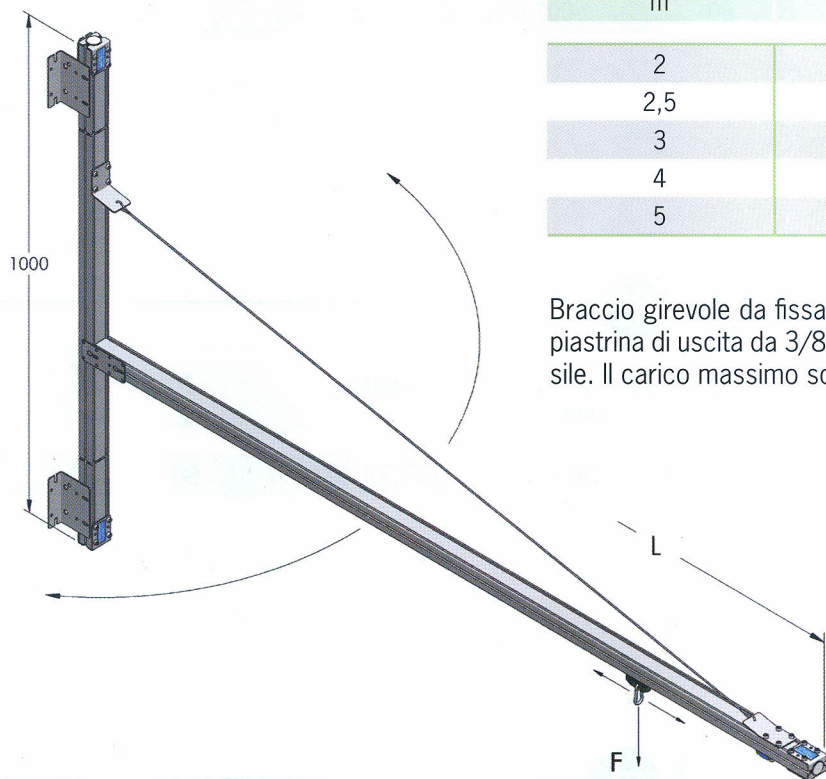
**SAB - VERSIONE DA BANCO**

L m	Codice N°	P Kg	 n°	
0,7	002 002 070	5,5	1	

Braccio girevole da fissare al banco di montaggio, completo di viti di fissaggio, piastrina di uscita da 3/8" e di pattino scorrevole per aggancio utensili.

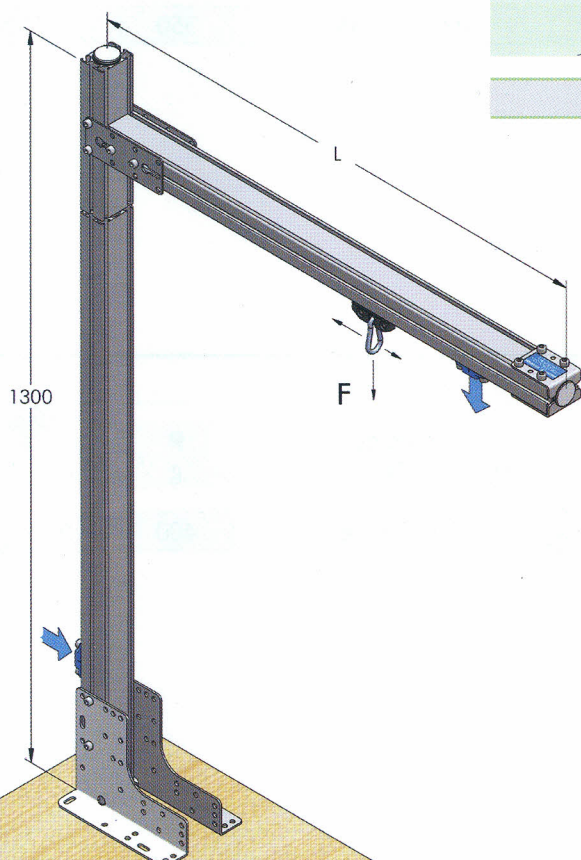

PATTINO SCORREVOLE SUPPLEMENTARE, COMPLETO DI MOSCHETTONE

HBS MAT

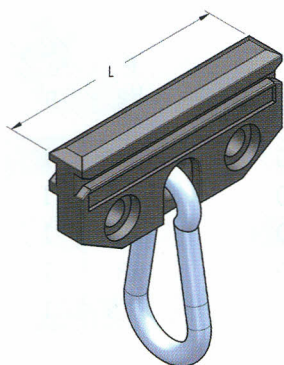

L mm	Codice N°	P g	n°
60	002 001 040	20	20



PIASTRINA DI USCITA SUPPLEMENTARE

HBS MAT

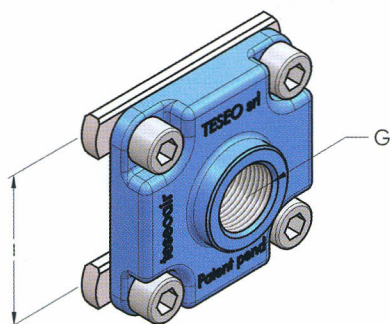

G	I mm	Codice N°	P g	n°
3/8" - BSP	36	003 001 934	80	20



PIASTRE PER FISSAGGIO DELL'ATS SU SAB

HBS ATS

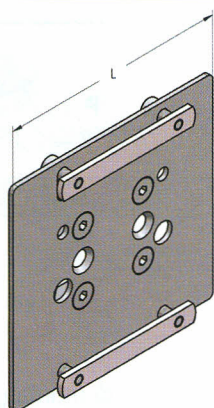

L mm	Codice N°	P g	n°
120	002 001 042	350	20



TUBO ELASTICO CON RACCORDI RAPIDI

SYS

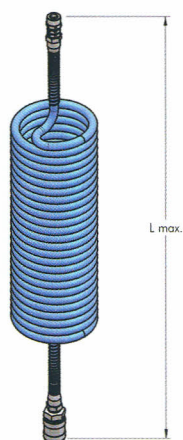

L m	Codice N°	P g	n°
5	001 003 065	400	10



SAB MONTAGGIO

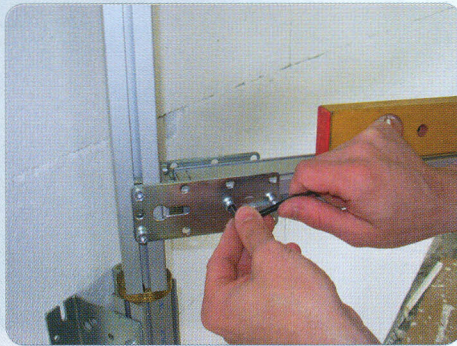
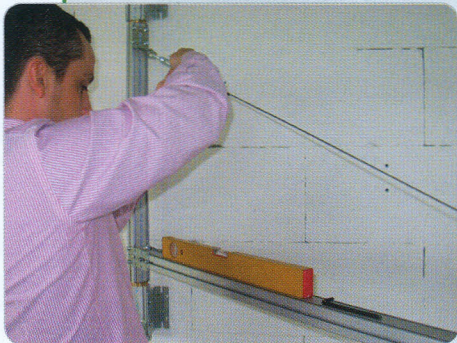
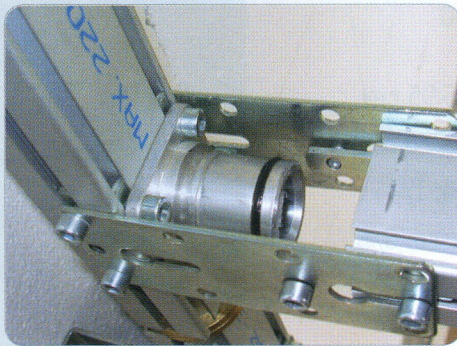
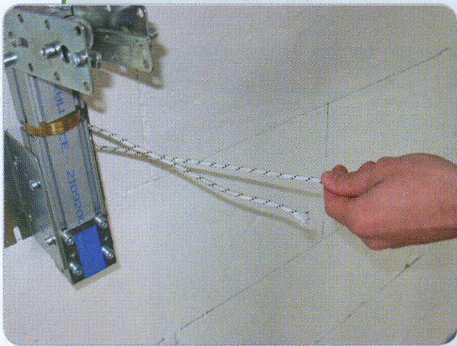
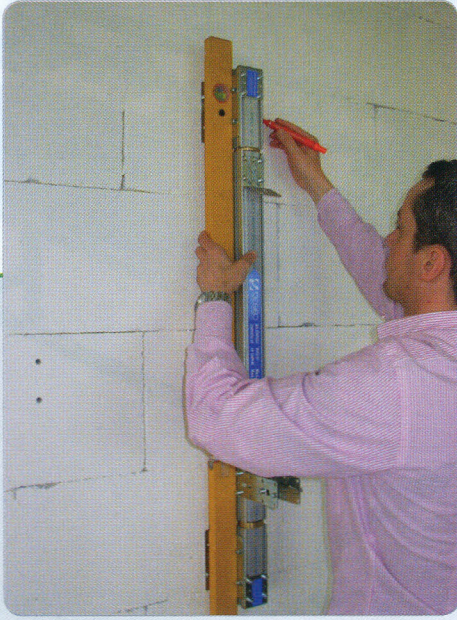

SAB

ABW